



WARNING:
CHOKING HAZARD-Small parts.
Not for children under 3 years.

AGES
5+
18531

3D Flash Art™

CONTENTS:

3D FLASH ART, plastic blister, 3 paint bottles, 4 design cards, 5 Bend and Build Sticks, and 4 one-ounce cans of PLAY-DOH® Brand Modeling Compound.

COMPOUND NET WT. 4 OZ. (123 g)

PAINT NET WT. 2.11 FLUID OZ. (62 ml)

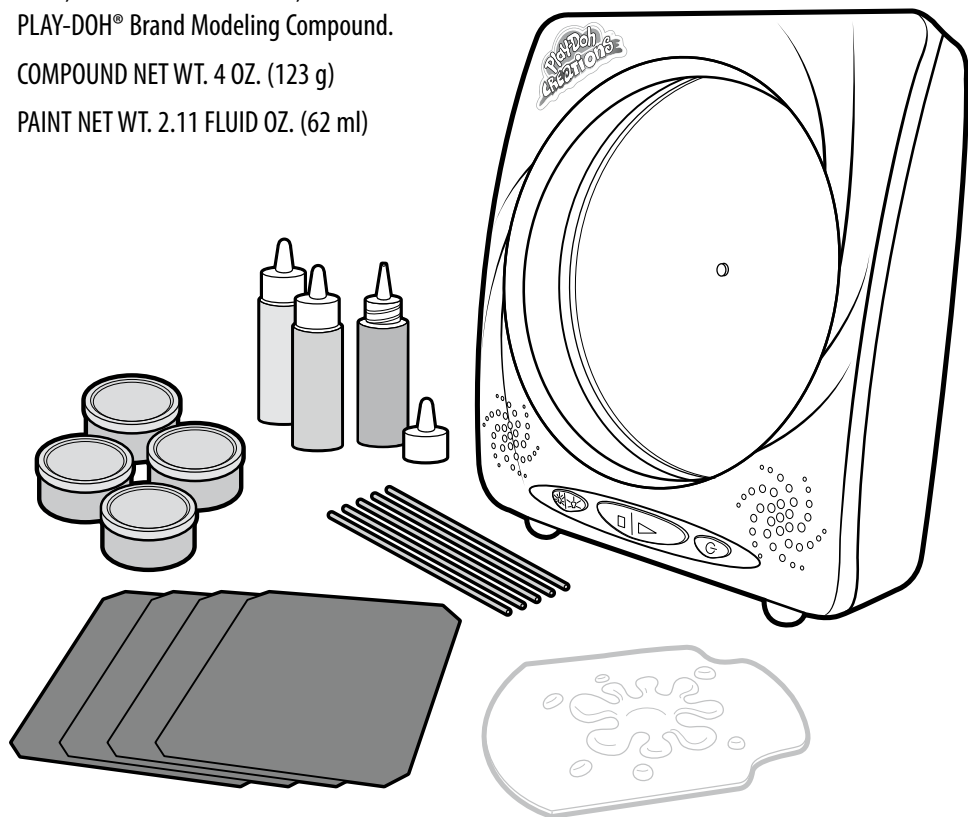

x4 ALKALINE BATTERIES REQUIRED
1.5V C or LR14 size
NOT INCLUDED

Phillips/cross head screwdriver (not included) needed to insert batteries.

Stain Advisement: Note that paint may stain some surfaces. Wash with soap and warm water.

BASICS:

Manually shuffle through the different strobe patterns

Automatic strobe start/stop

On/Off

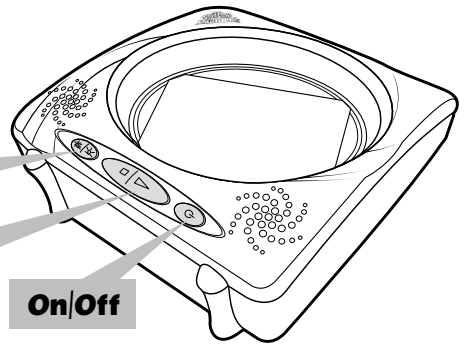

There are all kinds of amazing designs you can make with the 3D FLASH ART toy. When you're ready to spin your designs, turn off the lights to get the full glowing effect!

CREATING DESIGNS WITH PAINT:

1. Secure a design card onto the spinner platform as shown. Make sure all four corners are secure.

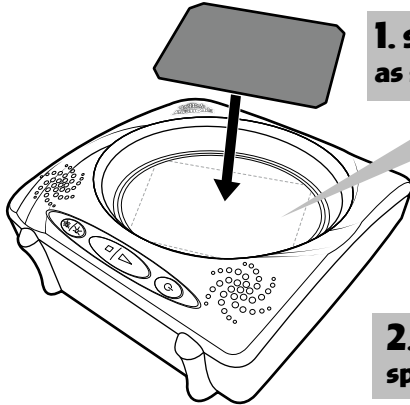

2. Press to start the spinning action!

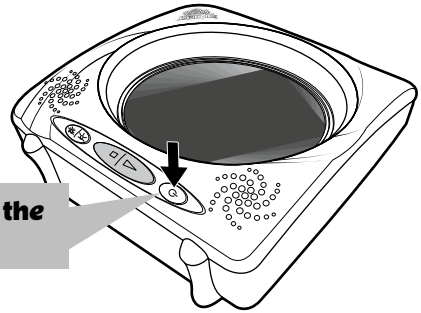

3. Drip paint onto the spinning design card. You can drip two paints at once for a different effect.

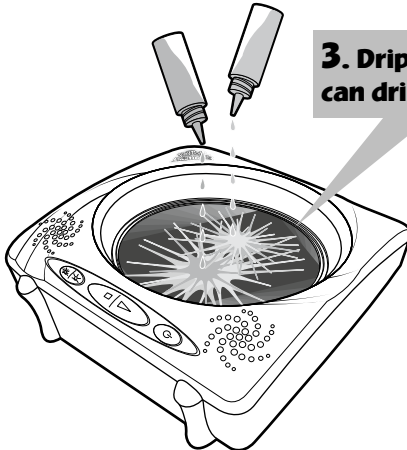

4. Once the paint has dried on your design card, you can stand the 3D FLASH ART toy upright and put it on display!

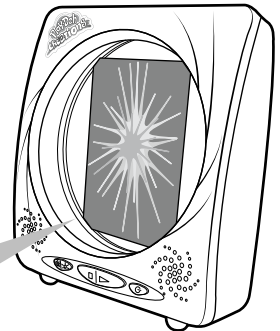

Try putting paint on your design card before placing it on the spinner platform.

You can also frame or hang your dry design cards.

CREATING DESIGNS WITH PLAY-DOH® COMPOUND:

1. Fill blister with compound.

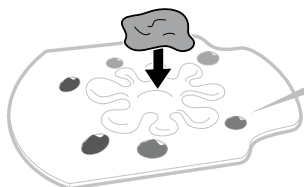

2. Secure it to the spinner platform as shown. Make sure both edges are secure under lip of spinner platform.

Tip: Insert the bigger edge first, then the smaller edge.

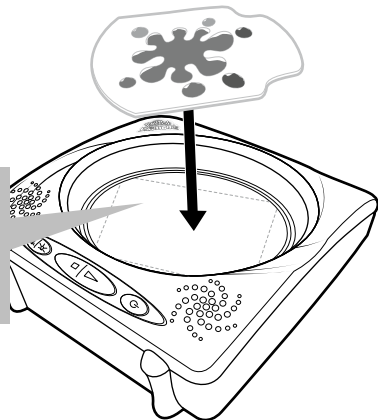

3. Press once to start the spinning action!

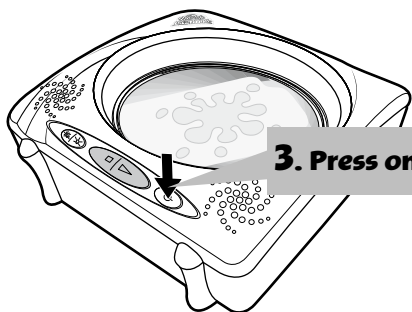

CREATING DESIGNS WITH BEND AND BUILD STICKS:

Your Bend and Build sticks will stick to the design cards, spinner platform and blister. Be sure to stick the whole Bend and Build Stick to the surface.

For the coolest effect, keep parts of your bendy sticks raised.

When a Bend and Build Stick starts to lose its stickiness, throw it away. Don't use wet paint with these sticks.

Look for more BEND AND BUILD STICKS and PLAY-DOH COMPOUND!

FUN IDEAS:

You can use a combination of PLAY-DOH compound, Bend and Build Sticks and painted design cards on your spinner. Be sure the paint has dried on your design cards before adding compound or sticks.

CLEANING UP:

Turn off the 3D FLASH ART toy and wipe with a damp paper towel to clean and prevent paint build-up.

TROUBLESHOOTING:

If the toy doesn't respond, change the batteries.

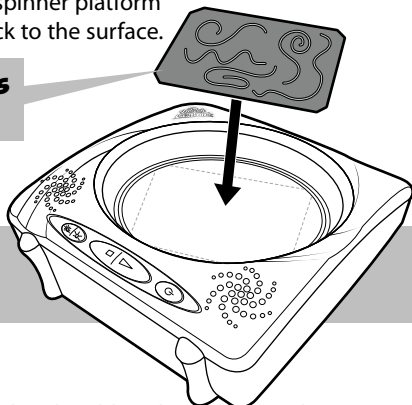

TO INSTALL BATTERIES:

Use a Philips/cross head screwdriver (not included) to loosen screw in battery compartment cover (screw remains attached to door). Insert 4 x 1.5V "C" or LR14 size alkaline batteries. Replace cover and tighten screw.

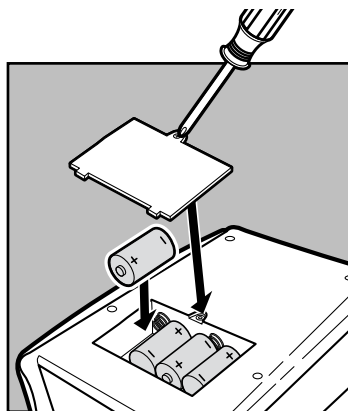

IMPORTANT: BATTERY INFORMATION



CAUTION:

1. Always follow the instructions carefully. Use only batteries specified and be sure to insert them correctly by matching the + and - polarity markings.
2. Do not mix old batteries and new batteries or standard (carbon-zinc) with alkaline batteries.
3. Remove exhausted or dead batteries from the product.
4. Remove batteries if product is not to be played with for a long time.
5. Do not short-circuit the supply terminals.
6. Should this product cause, or be affected by, local electrical interference, move it away from other electrical equipment. Reset (switching off and back on again or removing and re-inserting batteries) if necessary.
7. **RECHARGEABLE BATTERIES:** Do not mix these with any other types of batteries. Always remove from the product before recharging. Recharge batteries under adult supervision. **DO NOT RECHARGE OTHER TYPES OF BATTERIES.**

FCC STATEMENT

This device complies with part 15 of the FCC Rules. Operation is subject to the following two conditions: (1) This device may not cause harmful interference, and (2) this device must accept any interference received, including interference that may cause undesired operation. This equipment has been tested and found to comply with the limits for a Class B digital device, pursuant to part 15 of the FCC Rules. These limits are designed to provide reasonable protection against harmful interference in a residential installation. This equipment generates, uses and can radiate radio frequency energy, and, if not installed and used in accordance with the instructions, may cause harmful interference to radio communications. However, there is no guarantee that interference will not occur in a particular installation. If this equipment does cause harmful interference to radio or television reception, which can be determined by turning the equipment off and on, the user is encouraged to try to correct the interference by one or more of the following measures:

- Reorient or relocate the receiving antenna.
- Increase the separation between the equipment and receiver.
- Consult the dealer or an experienced radio/TV technician for help.

CAUTION: Changes or modifications to this unit not expressly approved by the party responsible for compliance could void the user's authority to operate the equipment.

PLAY-DOH and the PLAY-DOH logo are trademarks identifying quality modeling compound products produced exclusively by Hasbro, Inc.



© 2010 Hasbro. All Rights Reserved.

TM & ® denote U.S. Trademarks.

U.S. Patent No. 6713624.

18531

P/N 7069670000

NOTICE TO PARENTS: CONTAINS WHEAT.

NONTOXIC. CONFORMS TO ASTM D-4236.